

Engineering & Innovation
Project development
Sales & Marketing

SMP Engineering
Buffalo Grove
USA

AVN1500T WITH EXTENSION KIT 1960

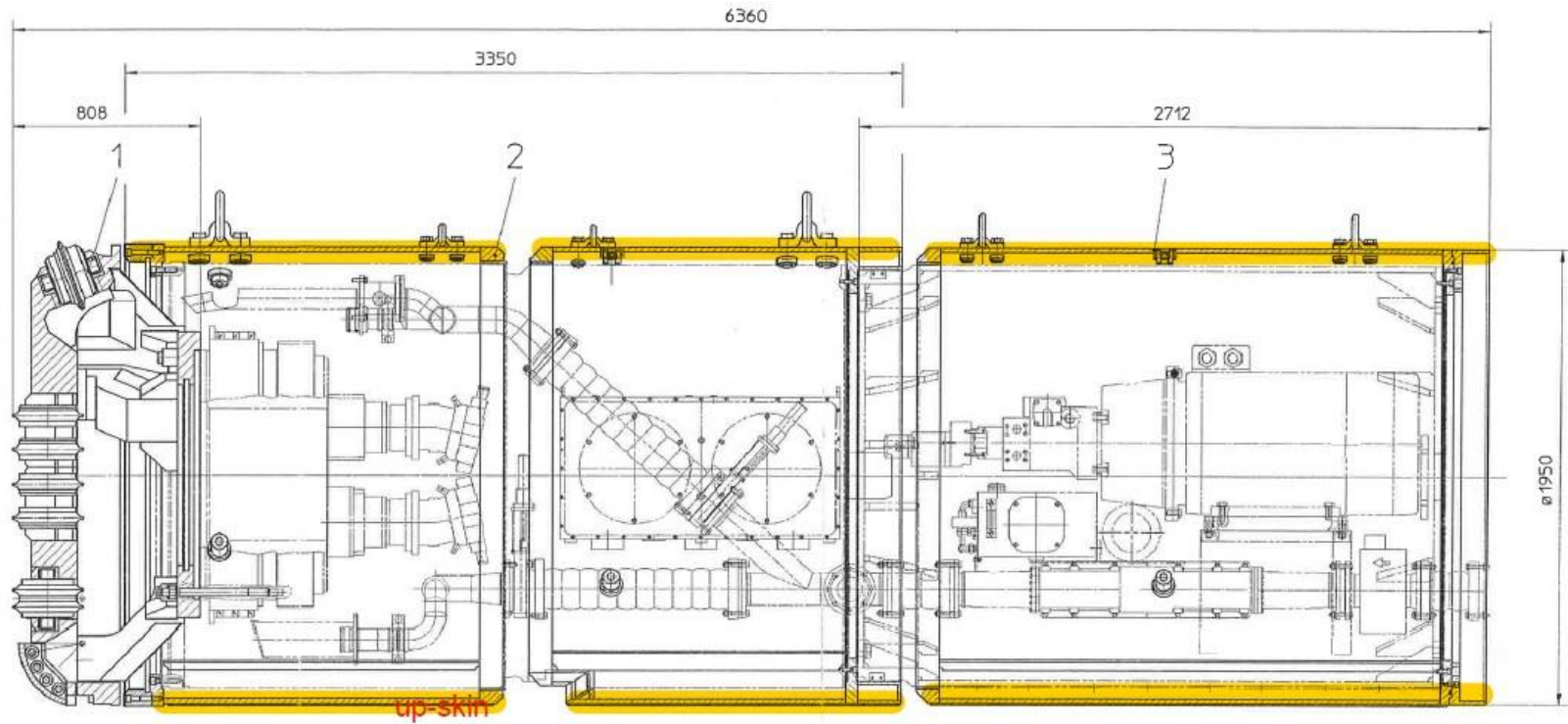

Gewicht	Felsbohrkopf	Aufdoppelmantel	Aufdopplung MR2	Gesamtgew.
Aufd.	5885kg	4820kg	2060kg	12765kg
Masch.	-	16020kg	8000kg	24020kg
Gesamtg.	5885kg	20840kg	10060kg	36785kg

CUTTERHEAD 1960

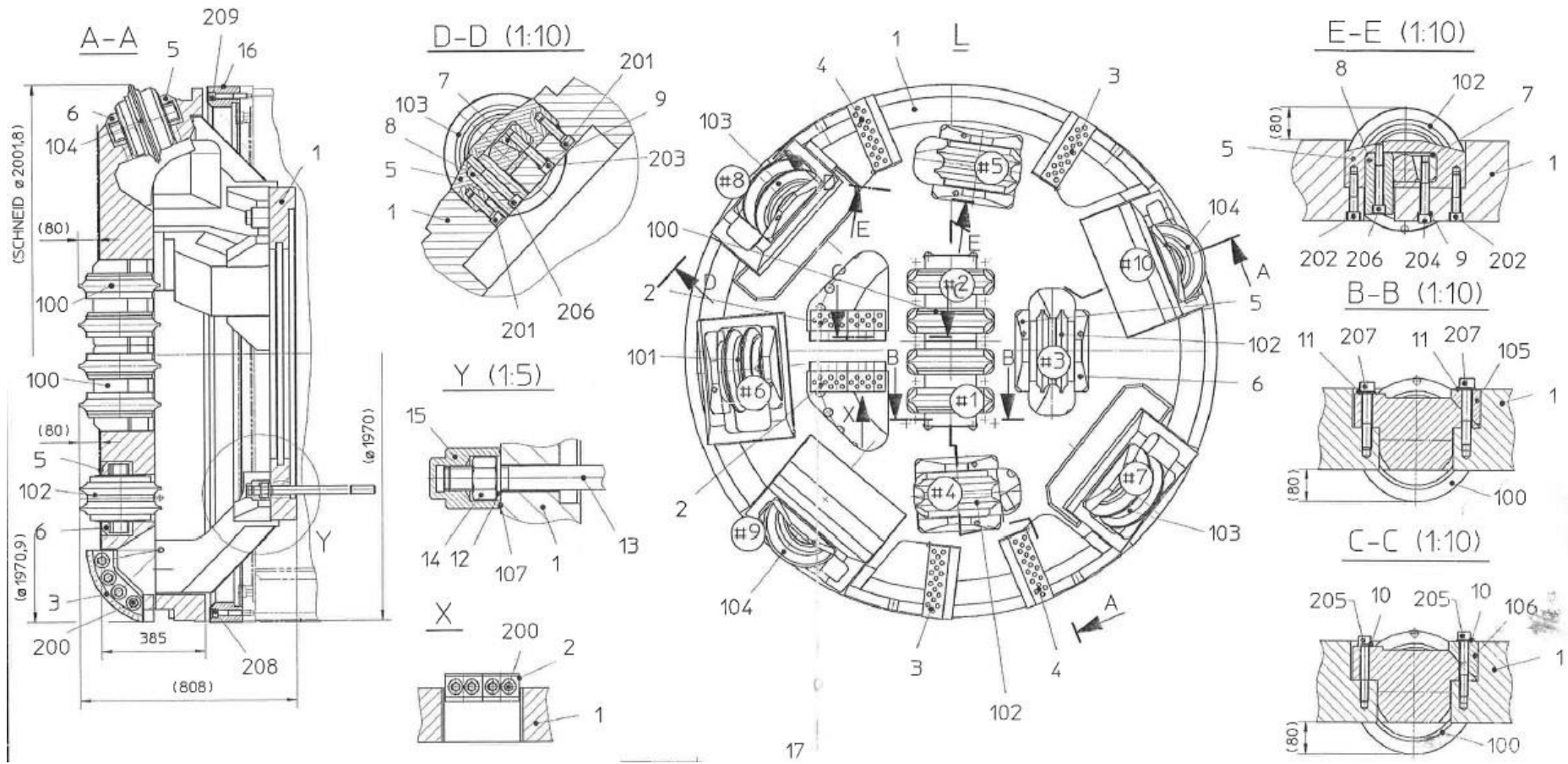

AVN1500 TB FRONT, CUTTERHEAD



AVN 1500 TB MACHINE REAR SIDE



POWERPACK PIPE





CONTROL CONTAINER



CONTROL CONTAINER





TELESKOP STATION 1960 MM, TAIL SKIN DRM 1805 MM







AVN 1500 TB DURING REFURBISHMENT



